

CLV-401A CAMERA LINK VIDEO SPLITTER

User's Manual

Document # 201058, Rev 0.1, 1/4/2012 **(preliminary)**

© Vivid Engineering
159 Memorial Drive, Suite F • Shrewsbury, MA 01545
Phone 508.842.0165 • Fax 508.842.8930
www.vividengineering.com • info@vividengineering.com

Table of Contents

1.	Introduction	1
1.1.	Overview	1
1.2.	Features	2
1.3.	Functional Description	3
1.4.	Typical Applications	5
1.4.1.	Standard Base Application	5
1.4.2.	Medium Application	6
1.4.3.	Cascaded Application	7
1.5.	Specifications	8
2.	Interface	9
2.1.	Front Panel Connections	9
2.2.	Rear Panel Connections	10
2.3.	Video Connectors	10
2.4.	Cable Shield Grounding	11
3.	Mechanical	12
3.1.	Dimensions	12
3.2.	External Power Supply	13
4.	Revision History	14

1. Introduction

1.1. Overview

The CLV-401A Camera Link¹ Video Splitter interfaces one Camera Link camera to two frame grabbers using standard Camera Link cables. This arrangement enables the addition of a second frame grabber for functions such as camera setup, secondary/parallel processing, and monitoring.

One frame grabber acts as master (i.e. primary) and provides control and communications to the camera. The secondary (slave) frame grabber receives camera video data only.

CLV-401A incorporates high-speed 85MHz interfaces and is compatible with all Camera Link “base” configuration cameras. “medium” configuration applications are supported using two CLV-401A’s. Multiple CLV-401A’s may be cascaded to support 4 or 8 frame grabbers.

The CLV-401A Camera Link Video Splitter is housed in sturdy, compact aluminum enclosures. A locking-plug power supply is optional.

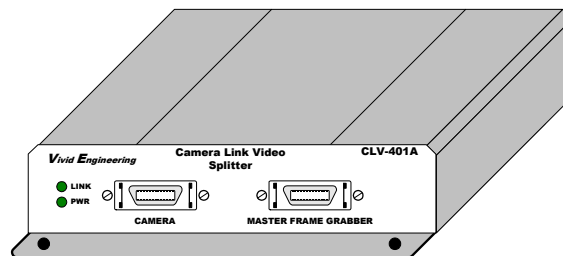

¹ The Camera Link interface standard enables the interoperability of cameras and frame grabbers, regardless of vendor. The Automated Imaging Association (AIA) sponsors the Camera Link program including the oversight Camera Link Committee, the self-certification program, and the product registry. The Camera Link specification may be downloaded from the AIA website, found at www.machinevisiononline.org

1.2. Features

- Interfaces one camera to two frame grabbers
- Second frame grabber can be used for camera setup, processing, monitoring, etc
- Uses standard Camera Link cables (not included)
- Supports Camera Link “base” configuration
- High-speed 85 MHz interface chipset, works with any base camera
- Minimal video data pass-through latency: 3 camera pixel clocks
- Minimal control/communication pass-through latency: under 5 nS
- Link status indicator
- Isolated DC power input
- “Medium” configuration support using two CLV-401A’s
- Multiple CLV-401A’s may be cascaded to support 4 or 8 frame grabbers
- Also acts as a repeater, doubling max distance between camera and frame grabbers
- Multi-nation power supply included, locking-plug power supply optional
- Sturdy, compact aluminum enclosure w/ mounting flange
- 3-year warrantee

1.3. Functional Description

A block diagram of the CLV-401A is provided in Figure 1-1. The CLV-401A interfaces one camera to two frame grabbers. One frame grabber is the master (primary), and one frame grabber is slave (secondary).

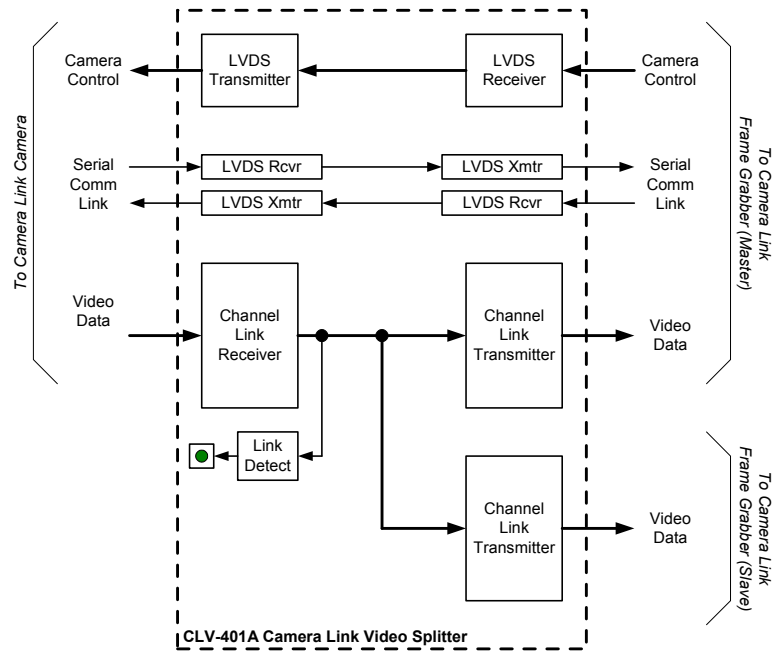

Figure 1-1: CLV-401A Block Diagram

The interface between the camera and the *master* frame grabber contains the entire Camera Link signal set defined in the Camera Link Specification for “base” configurations. This consists of video data, camera control, and serial communications. The master frame grabber receives video data from the camera, and can also control and communicate with the camera.

The interface between the camera and the *slave* frame grabber contains only the video data signals. The slave frame grabber receives video data, but cannot control or communicate with the camera.

The CLV-401A incorporates high-speed (85MHz) interfaces and is compatible with any “base” configuration camera. “Medium” configuration applications are supported using two CLV-401A’s in parallel. The CLV-401A does not support the Camera Link “full” configuration.

The latency (i.e. delay) of the video, control, and communication signals passing through the CLV-401A is minimal. This is an important criteria in time-critical applications. See Table 1.1 for the latency specifications.

CLV-401A also acts as a repeater and doubles the maximum separation between the camera and the frame grabbers.

A front-panel link status indicator illuminates when the camera video signal is detected. The front panel also includes a power indicator.

The CLV-401A is powered by an external wall plug-in power supply. A multi-nation power supply is standard. Optionally, the CLV-401A is available with a locking-plug power supply. The locking plug reduces the risk of accidental disconnection from the rear-panel power jack. The CLV-401A is also available without power supply.

The CLV-401A DC power input is electrically isolated from the internal circuitry. This feature ensures compatibility with user power systems.

1.4. Typical Applications

1.4.1. Standard Base Application

A standard CLV-401A base application is shown in Figure 1-2. A Camera Link “base” configuration camera is connected to a single CLV-401A via a standard Camera Link cable. Two additional Camera Link cables are then used to connect the CLV-401A to the master and slave Camera Link frame grabbers.

The master frame grabber provides camera control and communications, and performs the primary processing functions. The slave frame grabber cannot control or communicate with the camera, but may be used for parallel processing, secondary processing, camera setup, monitoring, etc.

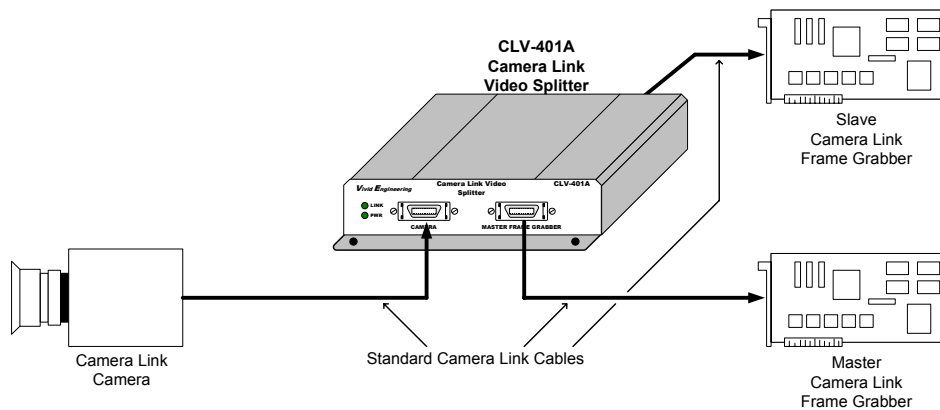

Figure 1-2: CLV-401A Standard Application (Base)

1.4.2. Medium Application

A CLV-401A “medium” application is shown in Figure 1-3. Medium configurations, in which two cables connect the camera to the frame grabber, are supported using two CLV-401A’s in parallel. A Camera Link “medium” configuration camera is connected to two CLV-401A’s via a pair of standard Camera Link cables. Four additional Camera Link cables are then used to connect the CLV-401A’s to the master and slave Camera Link frame grabbers.

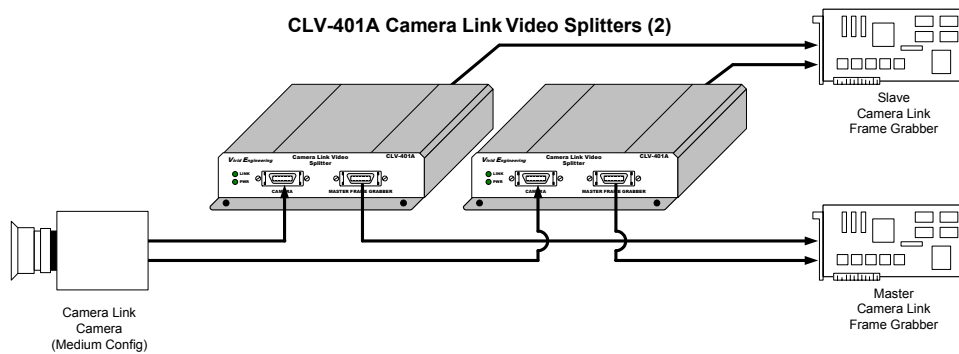

Figure 1-3: CLV-401A “Medium” Application

1.4.3. Cascaded Application

Multiple CLV-401A's may be cascaded to support four or eight frame grabbers. An application in which three CLV-401A's are cascaded to interface four frame grabbers to a Camera Link base configuration camera is shown in Figure 1-4. Seven standard Camera Link cables are used to interconnect the equipment. Note that one frame grabber is the master, and all remaining frame grabbers are slaves.

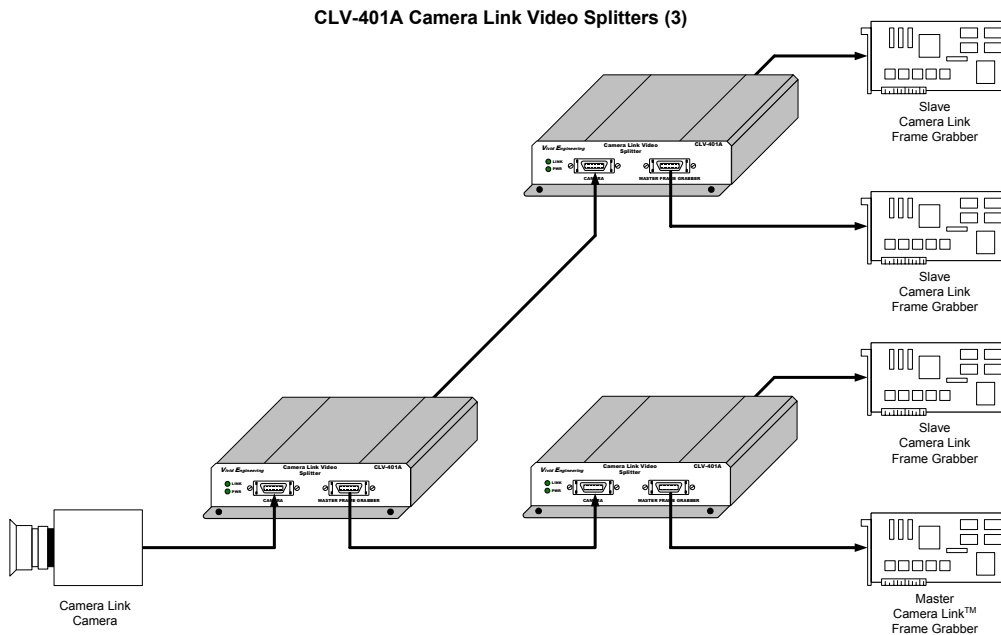

Figure 1-4: CLV-401A Cascaded Application

1.5. Specifications

Table 1-1: CLV-401A Specifications

Feature	Specification
Video Interfaces	Camera Link "base" configuration
Video Connectors	26-pin MDR type
Frequency Range	20 - 85 MHz
Latency	Video path: 3 camera pixel clock cycles Control & communication: 5ns max
Power Supply	Universal wall style w/ outlet plug set
Power Plug	2.1 x 5.5 mm, center-positive. Locking style optional.
Power Requirements	4.5 – 9 VDC, internally isolated 230 mA @ 5 VDC (typical)
Cabinet Dimensions	5.28" (L) x 1.18" (H) 5.12" (D)
Weight	11 oz
Operating Temperature Range	0 to 50° C
Storage Temperature Range	-25 to 75° C
Relative Humidity	0 to 90%, non-condensing

2. Interface

2.1. Front Panel Connections

The CLV-401A Camera Link Video Splitter front panel is shown in Figure 2-1. The front panel contains two 26-pin MDR video connectors; one for connecting to the camera and one for connecting to the master frame grabber. The front panel also incorporates LED power and link status indicators.

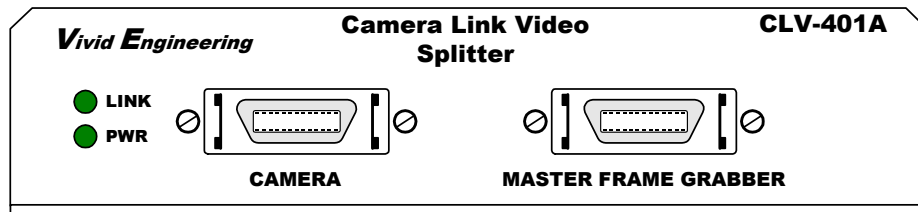

Figure 2-1: CLV-401A Front Panel

2.2. Rear Panel Connections

The CLV-401A Camera Link Video Splitter rear panel is shown in Figure 2-2. The rear panel contains the 26-pin MDR video connector for the slave frame grabber, and the DC power jack.

The DC power jack accepts either a standard 2.1 x 5.5 mm barrel-style power plug or a special locking plug. The locking plug has bayonet-style “ears” on the barrel. Once inserted, the plug is turned ¼ turn clockwise. This locks the connection and provides retention. Plug polarity is center-positive. The locking power plug is Philmore part number 2150.

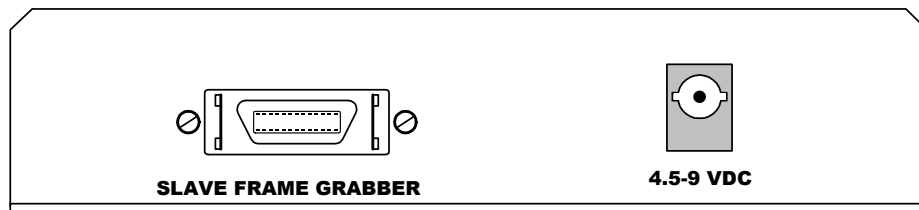

Figure 2-2: CLV-401A Rear Panel

2.3. Video Connectors

The MDR-26 video connectors and signal assignments comply with the Camera Link “base” configuration. The *camera* connector signal assignments correspond to the frame grabber interface defined in the Camera Link Specification. Conversely, the *frame grabber* connector assignments are as defined for the camera interface in the Camera Link Specification. This arrangement provides compatibility with standard Camera Link cables.

2.4. Cable Shield Grounding

Camera and frame grabber cable “outer” shields are connected to the CLV-401A aluminum case. Case and endplate contacting surfaces are unpainted, providing a Faraday cage to shield internal circuitry. The case is isolated from the CLV-401A circuitry and the cable “inner” shields, avoiding possible safety concerns.

The camera and frame grabber cable “inner” shields connects to circuit digital ground, maintaining signal reference levels between the camera and the CLV-401A, and between the CLV-401A and the frame grabbers.

3. Mechanical

3.1. Dimensions

The CLV-401A Camera Link Video splitter cabinet dimensions are shown in Figure 3-1.

The CLV-401A is housed in a sturdy aluminum enclosure. The body is extruded aluminum, with detachable front and rear endplates. The enclosure incorporates a mounting flange. The flange contains four predrilled holes (0.15" diameter) for convenient equipment mounting. A mounting footprint drawing is provided in Figure 3-2.

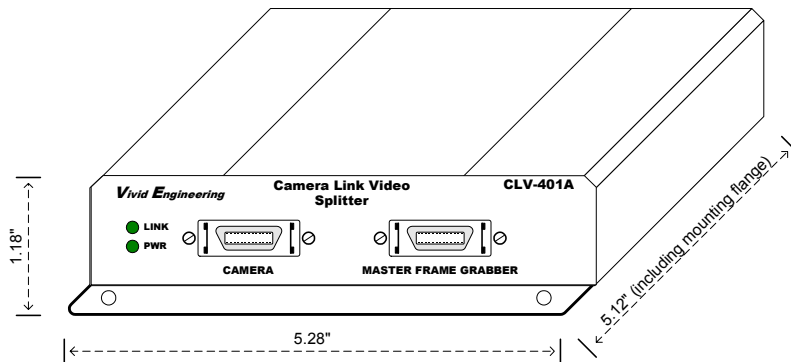

Figure 3-1: CLV-401A Cabinet Dimensions

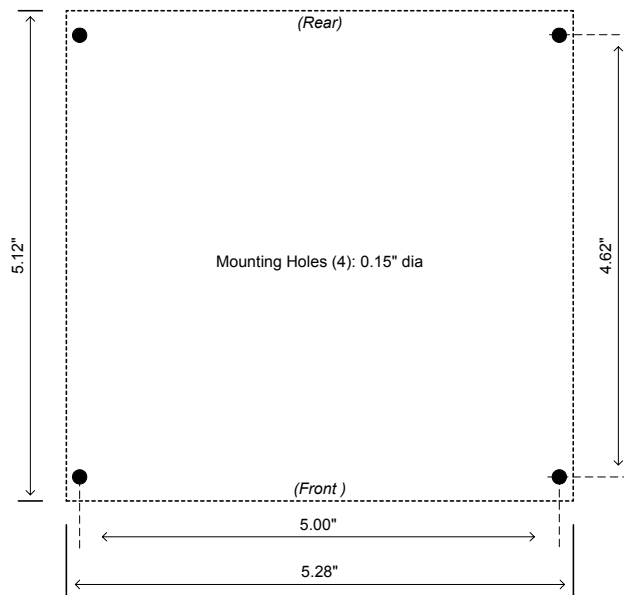

Figure 3-2: CLV-401A Mounting Footprint

3.2. External Power Supply

The CLV-401A is powered by 4.5 – 9.0 VDC and incorporates a 2.1 x 5.5 mm DC power jack that accepts either a standard barrel-style power plug, or a special locking version (see Section 2.2). Power plug polarity is center-positive.

The CLV-401A includes a multi-nation wall-mount power supply that handles a wide power range (90-264 VAC, 47-63 Hz) and comes with a set of outlet plugs suitable for most countries (US, Europe, UK, etc). The CLV-401A may also be purchased with a locking-plug power supply, or without power supply.

4. Revision History

Table 5-1: CLV-401A User's Manual Revision History

Document ID #	Date	Changes
201058-0.1	1/4/12	Preliminary release of manual