

CLT-371A CAMERA LINK TRANSLATOR

User's Manual

Document # 201488, Rev 0.1, 8/31/2023 (**preliminary**)

© Vivid Engineering
415 Boston Turnpike, Suite 305 • Shrewsbury, MA 01545
Phone 508.842.0165 • Fax 508.842.8930
www.vividengineering.com • info@vividengineering.com

Table of Contents

1.	Introduction	1
1.1.	Description	1
1.2.	Features	2
1.3.	Block Diagram	3
1.4.	Limitations	4
2.	Operation	5
2.1.	Camera Connection	5
2.1.1.	PoCL Camera Support	5
2.2.	HD-SDI Connection	6
2.2.1.	HDMI / DVI-D Output Support	6
2.3.	Configuration Switches	6
2.3.1.	PIXEL_DEPTH	9
2.3.2.	DVAL_ENABLE	9
2.3.3.	COLOR	9
2.3.4.	BAYER_PATTERN	9
2.3.5.	WHITE_BALANCE_ENABLE	10
2.3.6.	WHITE_BALANCE_WRITE_ENB	10
2.3.7.	WHITE_BALANCE_SELECT	10
2.3.8.	WHITE_BALANCE_TRIGGER	11
2.3.9.	FORMAT	11
2.3.10.	FRAME_RATE	11
2.3.11.	CENTER_DISABLE	11
2.3.12.	TEST_PATTERN	11

2.3.13.	SYNC_SHAPE	13
2.3.14.	SYNC_INVERT	13
2.3.15.	SYNC_ON_CC1	14
3.	Examples	15
3.1.	Stand-Alone Application	15
3.2.	Camera Control Application	16
3.3.	Video Splitter Application	17
3.4.	Configuration Example	18
4.	Specifications	20
5.	Interface	21
5.1.	Front Panel Connections	21
5.2.	Rear Panel Connections	23
6.	Mechanical	23
6.1.	Dimensions	24
6.2.	External Power Supply	25
7.	Revision History	25

1. Introduction

1.1. Description

The CLT-371A Camera Link Translator converts Camera Link to HD-SDI, enabling the use of Camera Link cameras with HD-SDI monitors and other equipment. The CLT-371A works with most color and monochrome base-configuration cameras. HD-SDI output is either 1920x1080 or 1280x720.

Features include automatic frame rate adaptation, Bayer white balance correction, camera synchronization support, and an RS-232 port for camera set-up and control. USB camera set-up and control is supported via an adapter.

No software or preprogramming is required. Configuration is via rear-panel switch settings.

PoCL cameras and HDMI / DVI-D output are supported using external adapters.

CLT-371A front-panel indicators identify when the unit is powered, when an active camera is connected, and when the camera is synchronized to the HD-SDI video output.

The CLT-371A is housed in a sturdy aluminum enclosure. A locking-plug power supply is optional.

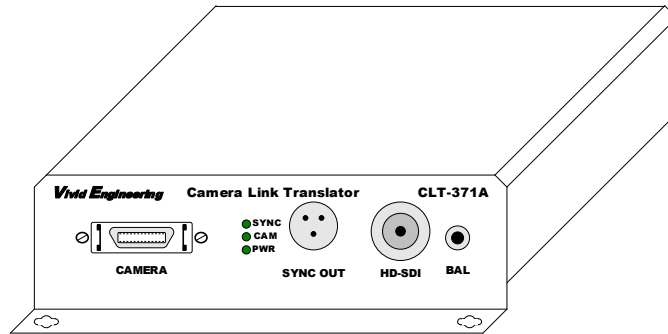

1.2. Features

- Enables use of Camera Link cameras with HD-SDI monitors and equipment
- *HDMI & DVI-D output via an external converter*
- Works with most Camera Link color and monochrome base-configuration cameras
- *PoCL cameras supported using Vivid CLR-102 adapter*
- HD-SDI 1920x1080 @ 29.97p or 30p, 1280x720 @ 59.94p or 60p
- Automatic frame rate adaptation; no camera synchronization required
- Bayer white balance correction
- Crop and center for images larger/smaller than 1920x1080 or 1280x720
- RS-232 port for camera set-up and control (or USB with external adapter)
- Configured via rear-panel switches, no software or programming required
- Camera synchronization support
- Test pattern generator
- Camera presence and synchronization indicators
- Multi-nation power supply included, locking-plug version optional
- Sturdy aluminum enclosure w/ mounting flange
- 3-year warrantee

1.3. Block Diagram

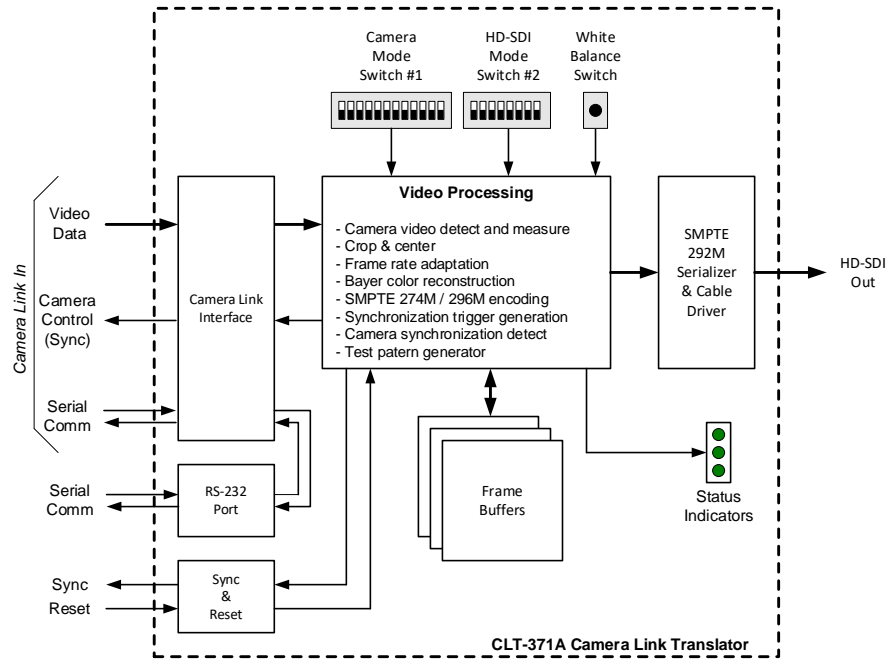

1.4. Limitations

The CLT-371A is a “standard product” converter from Camera Link to HD-SDI and works with *most* base-configuration cameras. However, Camera Link cameras vary widely. The following is a list of requirements and limitations when using the CLT-371A:

Minimum Image Size:

The camera image must be at least 128 pixels per line, and 4 lines per frame (128x4).

Dual-Tap Limitation:

The CLT-371A only supports dual-tap images with “interleaved” format. This is the most common dual-tap format in which two adjacent pixels from the same video line are transmitted at a time. No other dual tap formats are supported.

Small Image Limitation:

Images smaller than the selected HD-SDI image size (1920x1080 or 1280x720) will be cropped to multiples of 128 pixels per line. Therefore when camera “X” dimension is \geq 128 pixels but less than the HD-SDI (1920 or 1280), the camera image will be cropped on the right side as necessary to reduce image “X” size to 128/256/384/512/640/768/896/1024/1152... pixels. Similarly, images smaller than the selected HD-SDI image size will be cropped to multiples of 4 lines per frame. Therefore when camera image “Y” dimension is \geq 4 pixels but less than HD-SDI (1080 or 720), the camera image will be cropped at the bottom as necessary to reduce image “Y” size to 4/8/12... pixels.

Large Image Limitation:

Camera images larger than 16K in the “X” dimension and/or 16K in the “Y” dimension are not supported.

Minimum Frame Rate Requirement:

Cameras with continuous frame rates less than 2 Hz are not supported.

Active Video Requirement:

The CLT-371A measures camera video (i.e. x/y dimensions) upon connection in order to determine processing requirements. A camera should be active (i.e. outputting video frames) when connected to the CLT-371A. Once measured and the front panel “CAM” light is green, camera frames may be suspended for purposes such as external triggering. The CLT-371A must be power cycled or the reset input asserted when camera settings affecting output image size are changed while the camera is already active.

No Zoom:

The CLT-371A does not perform zoom in or zoom out. Images larger/smaller than 1920x1080 or 1280x720 are handled using crop and center only.

2. Operation

2.1. Camera Connection

The CLT-371A is designed to work with most Camera Link *base* configuration cameras. A “base” configuration camera can be identified by the existence of only one Camera Link connector.

The CLT-371A incorporates the standard Camera Link “MDR” (i.e. full size). A standard Camera Link cable is used to connect the camera to the CLT-371A.

Cameras with the “mini” (i.e. HDR/SDR) Camera Link connector are connected to the CLT-371A using readily-available adapting cables with an MDR connector on one end and an HDR/SDR on the other.

2.1.1. PoCL Camera Support

The CLT-371A does not support PoCL (Power over Camera Link) cameras. PoCL cameras can be used by inserting the Vivid Engineering CLR-102 Camera Link PoCL Repeater/Adapter between the camera and the CLT-371A. An example is shown in Section 3.1.

2.2. HD-SDI Connection

The CLT-371A incorporates a 75 ohm BNC connector on the front panel for connection to HD-SDI monitors or other HD-SDI equipment.

75 ohm video BNC cables must be used that are HD-SDI performance rated to ensure video signal integrity.

2.2.1. HDMI / DVI-D Output Support

HDMI or DVI-D output is supported by placing a converter between the CLT-371A and the HDMI / DVI-D equipment. Inexpensive HD-SDI to HDMI converters are available from several manufacturers.

2.3. Configuration Switches

The CLT-371A requires no software or preconfiguration. Configuration is via the two rear-panel mode switches.

The “Mode 1” slide switch has 12 positions and identifies camera characteristics.

The “Mode 2” slide switch has 8 positions and selects HD-SDI output characteristics.

The mode switches may be changed at any time. In some cases, cycling the CLT-371A power or asserting the reset input may be needed following changes.

CLT-371A “Mode 1” and “Mode 2” switch assignments are shown in Figure 2-1 and 2-2, respectively. The switch settings are explained in the following sections.

It is suggested to start with all switches “down” which tends to be the more common or default position.

A front-panel pushbutton switch is used during white balance setup.

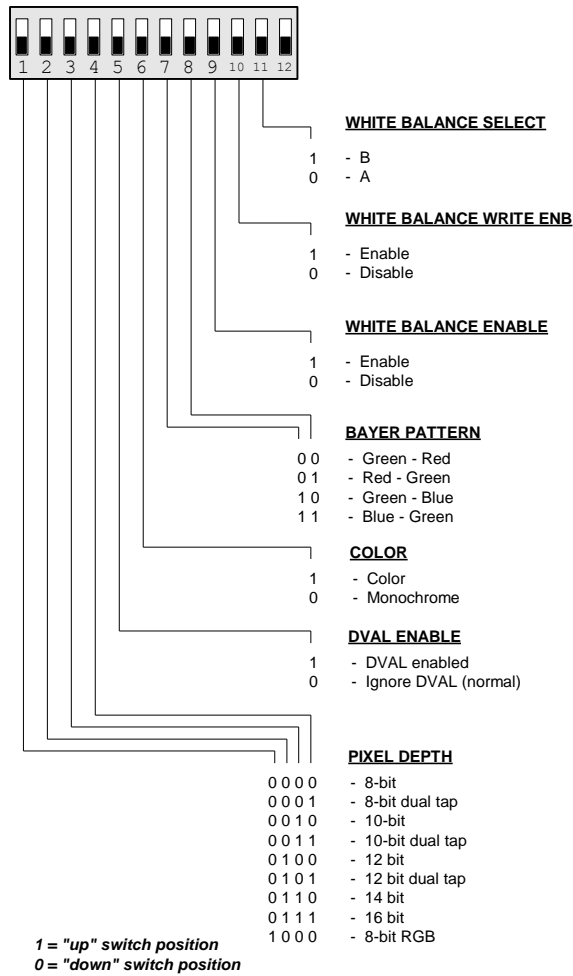

Figure 2-1: Mode 1 Switch Definition (Camera)

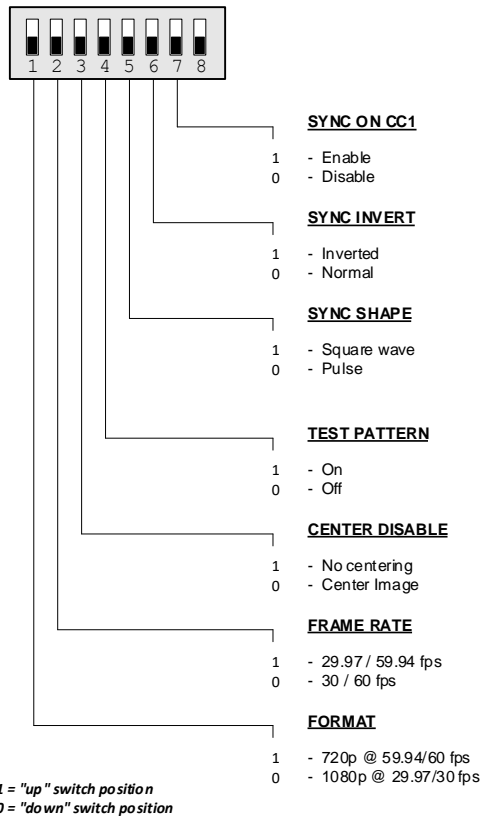

Figure 2-2: Mode 2 Switch Definition (HD-SDI)

2.3.1. PIXEL_DEPTH

Positions 1-4 of the Mode 1 switch specify camera pixel depth as defined in Figure 2-1.

The CLT-371A supports all base-configuration pixels depths per the Camera Link Specification.

Pixel depth is specified in the camera data sheet or user manual.

2.3.2. DVAL_ENABLE

Position 5 of the Mode 1 switch determines how the Data Valid (DVAL) signal is handled.

The DVAL (Data Valid) signal is part of the Camera Link interface and acts as a data qualifier. Per the Camera Link specification, when DVAL is high the video data (i.e. pixel data, frame valid, line valid) is valid and should be acquired/processed. When DVAL is low the current video data should be ignored.

In practice, most Camera Link cameras do not use DVAL (or do not use DVAL properly) and the default (down) switch position causes the CLT-371A to ignore the signal. All received video data is considered valid.

Some cameras use DVAL properly for purposes such as region of interest (ROI) output. For these cameras the DVAL_ENABLE switch should be raised in order to process the signal.

It is suggested to initially set this position down, then experiment if necessary. The camera user manual may provide information regarding DVAL signal use.

2.3.3. COLOR

Positions 6 of the Mode 1 switch identifies color cameras as defined in Figure 2-1.

2.3.4. BAYER_PATTERN

Mode Switch 1 positions 7-8 in Figure 2-1 identify the color pattern for a Bayer camera.

Bayer cameras send color pixels in varying sequences. The selections shown in Figure 2-1 represent the first two pixels of the first line received from the camera. For instance, setting positions 7&8 “down” selects the “Green-Red” pattern. This setting is for cameras that send green for the 1st pixel in the first line, then red for the second pixel of the 1st line, etc.

2.3.5. WHITE_BALANCE_ENABLE

Mode Switch 1 position 9 enables white balance correction for Bayer color cameras.

When the WHITE_BALANCE_ENABLE switch is raised, white balance processing is performed on the incoming video using previously-stored correction coefficients. The correction is performed using one of the two stored correction coefficient sets (A or B) as selected by the WHITE_BALANCE_SELECT switch.

When the WHITE_BALANCE_ENABLE switch is lowered, white balance correction is disabled. The video output to HD-SDI is as received from the camera (i.e. Bayer reconstructed, but without white balance correction).

2.3.6. WHITE_BALANCE_WRITE_ENB

Mode Switch 1 position 10 is the white balance coefficient write enable.

The WHITE_BALANCE_WRITE_ENB switch enables storage of white balance coefficients when the front-panel trigger switch is pressed (see Section 3.4 for an example white balance sequence). The switch arms the white balance trigger switch on the CLT-371A front panel. Placing WHITE_BALANCE_WRITE_ENB low (disabled) avoids unwanted acquisition of balance correction data if the trigger switch is accidentally pressed.

2.3.7. WHITE_BALANCE_SELECT

Mode Switch 1 position 11 is the white balance select.

The white balance select switch determines which balance coefficient set (A or B) stored in the CLT-371A is used when Bayer white balance correction is enabled.

The switch setting also determines which coefficient set is updated during a white balance coefficient load sequence (see Section 3.4 for example sequence).

2.3.8. WHITE_BALANCE_TRIGGER

The WHITE_BALANCE_TRIGGER pushbutton switch is located on the front panel.

Pressing WHITE_BALANCE_TRIGGER causes coefficient data to be stored to non-volatile memory in the CLT-371A during the white balance load sequence. See Section 3.4 for an example load sequence.

2.3.9. FORMAT

Mode Switch 2 position 1 selects the HD-SDI format as defined in Figure 2-2.

2.3.10. FRAME_RATE

Mode Switch 2 position 2 selects the HD-SDI as defined in Figure 2-2.

2.3.11. CENTER_DISABLE

Mode Switch 2 position 3 disables automatic image centering.

Normally, the CLT-371A centers images that are smaller in X and/or Y dimension than the selected HD-SDI format. If the CENTER_DISABLE switch is raised, centering is disabled and the image will be positioned at the top-left corner.

CENTER_DISABLE also applies to images larger in X and/or Y. Normally the CLT-371A centers images that are larger than the selected HD-SDI format (i.e. crops images evenly left and right, and top and bottom). If centering is disabled (CENTER_DISABLE is raised), the top-left portion of the larger image is displayed (i.e. cropping is performed on left and bottom only).

2.3.12. TEST_PATTERN

Mode Switch 2 position 4 selects test pattern output.

When TEST_PATTERN is raised, the CLT-371A outputs the color bars test pattern shown below. The test pattern is convenient way to check the connection between CLT-371A and HD-SDI equipment.

Test pattern format and frame rate are as specified by the FORMAT and FRAME_RATE switches.

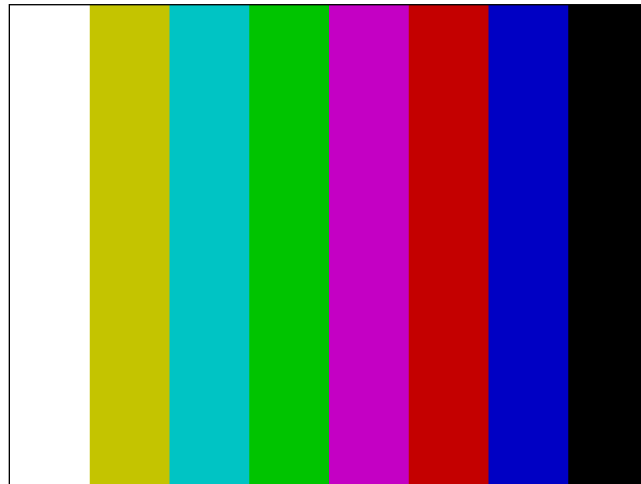

Figure 2-3: Color Bars Test Pattern

2.3.13. SYNC_SHAPE

Mode Switch 2 position 5 in selects the wave shape of the synchronization output signal.

The CLT-371A generates a synchronizing signal that is aligned with the start of the HD-SDI video frames. This signal is available for use by the camera, frame grabbers, or other acquisition equipment in order to synchronize acquisition to the HD-SDI video output.

The synchronization signal is output continuously to the circular connector and is an LVTTTL signal level. The synchronization signal is also sent to the Camera Link camera via camera control CC1 when the SYNC_ON_CC1 switch is raised (see next two sections).

When SYNC_SHAPE is low, the synchronization signal is a 1ms positive pulse with rising edge coincident with the start of HD-SDI frames.

When SYNC_SHAPE is high, the synchronization signal is a 50% duty cycle square wave with rising edge coincident with the start of HD-SDI frames.

2.3.14. SYNC_INVERT

Mode Switch 2 position 6 in inverts the synchronization signal described in the prior section.

This feature supports varying camera synchronization requirements/characteristics.

2.3.15. SYNC_ON_CC1

Mode Switch 2 position 7 in enables synchronization output to the camera.

When SYNC_ON_CC1 is raised, the synchronization signal specified by SYNC_PHASE and SYNC_INVERT is also sent to the camera via the CC1 camera control signal in the Camera Link interface. When SYNC_ON_CC1 is low, the CC1 signal is a static 0.

Note all other CC signals sent to the camera (CC2, CC3, CC4) are always static 0.

3. Examples

3.1. Stand-Alone Application

A stand-alone application is shown in Figure 3-1.

The CLT-371A mode switches are configured per camera characteristics and desired HD-SDI output. There is no ability to communicate with the camera in this setup, so the camera must power-up into the desired mode.

This figure also illustrates how PoCL (Power over Camera Link) cameras and/or HDMI / DVI-D output can be supported via external adapters.

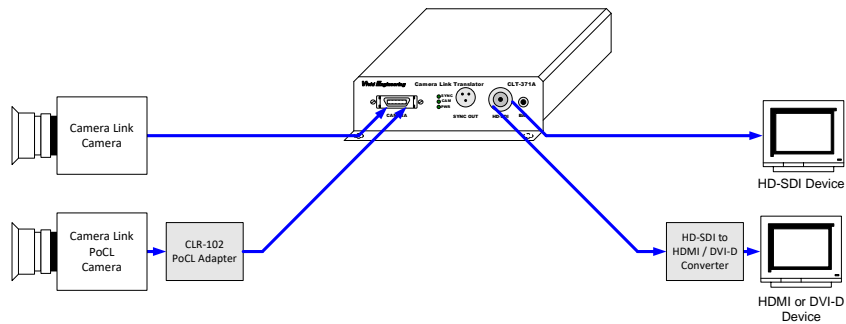

Figure 3-1: Stand Alone Application

3.2. Camera Control Application

An application with camera control software is shown in Figure 3-2.

The CLT-371A mode switches are configured per camera characteristics and desired HD-SDI output. Camera control software running on the PC communicates with the camera via the CLT-371A RS-232 port.

Inexpensive USB to RS-232 adapters are available for PCs that do not have an RS-232 port.

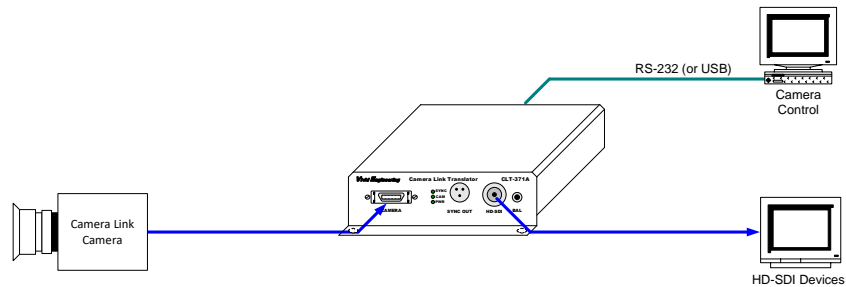

3.3. Video Splitter Application

A video splitter application is illustrated in Figure 3-4.

In this example the Camera Link signal is split using a Vivid Engineering CLV-401A Camera Link Video Splitter. The “*master*” output of the splitter is sent to a Camera Link frame grabber. The master interface incorporates the camera control and serial communication signals, so any camera communication or synchronization is via the frame grabber. The splitter “*slave*” port connects to the CLT-371A.

This illustrates a typical application where the CLT-371A / CLV-401A are added to an existing Camera Link system for HD-SDI monitoring, recording, etc.

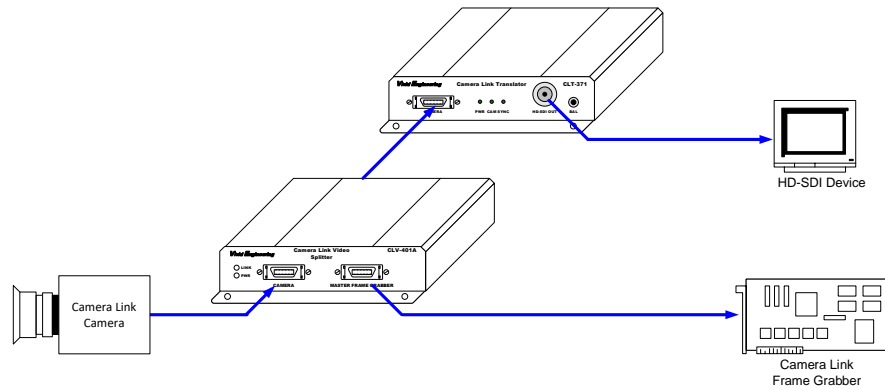

3.4. Configuration Example

This section provides a CLT-371A configuration example incorporating Bayer white balance correction and camera synchronization.

Camera Characteristics:

- 1920 x 1080
- 35 FPS
- 12-bit, dual-tap
- Bayer color
- Supports synchronization triggers via CC1

Desired HD-SDI Output:

- 1920x1080
- 29.97 FPS
- Color
- Camera synchronized to the HD-SDI output
- Acquire and utilize white balance coefficients

Note that camera synchronization is possible in this example because the camera maximum frame rate of 35 FPS is faster than the 29.97 FPS HD-SDI rate. While the CLT-371A incorporates automatic frame rate adaptation and it is not necessary for the frame rates to match, camera synchronization can be desirable and is included in this example.

Key Settings:

- PIXEL_DEPTH = 0101
- COLOR = 1
- BAYER_PATTERN = 00 (Green-Red pattern for this example)
- WHITE_BALANCE_ENABLE = 0 (correction initially disabled for this example)
- FORMAT = 0
- FRAME_RATE = 1
- SYNC_SHAPE = 0 (camera requires 1ms pulses for this example)
- SYNC_INVERT = 1 (camera requires negative pulses for this example)
- SYNC_ON_CC1 = 1

Following the above setup, color video (slightly green since white balance is disabled) is observed on the HD-SDI monitor. The front-panel “CAM” LED is on indicating an active camera connection. The “SYNC” LED is also on indicating the camera is synchronized to the HD-SDI output.

The following steps are performed in sequence to acquire white balance correction coefficients. In preparation, a flat field (i.e. all white) is placed in front of the camera. The camera lens is adjusted for a bright image, but not saturated.

- WHITE_BALANCE_ENABLE = 1
- WHITE_BALANCE_SEL = 0 (coefficient set A for this example)
- WHITE_BALANCE_WRITE_ENB = 1 (enables front panel balance switch)
- Press front panel “Balance” switch
- WHITE_BALANCE_WRITE_ENB = 0 (disables front panel balance switch)

When the balance switch is pressed, new coefficients are stored to non-volatile memory and applied to the video input. The slightly-green flat field becomes white as the balance coefficients are utilized. WHITE_BALANCE_WRITE_ENB is set to 0 at the end of this sequence to prevent accidental coefficient overwrite.

Corrected vs uncorrected images may be compared by toggling the WHITE_BALANCE_ENABLE switch. The CLT-371A coefficients are non-volatile and will remain until overwritten via the above sequence.

4. Specifications

Table 4-1: CLT-371A Specifications

Feature	Specification
Camera Interface	Camera Link "base" configuration, 20-85 MHz, MDR female connector
Supported Camera Formats	<i>Monochrome area scan:</i> - 8/10/12/14/16-bit single tap - 8/10/12-bit dual-tap <i>Color area scan:</i> - 8-bit RGB - 8/10/12-bit Bayer (single or dual tap)
HD-SDI Interface	SMPTE-292M serial digital, 75 ohm BNC connector
HD-SDI Formats	<i>User-selectable:</i> - 1920x1080 progressive, 30 or 29.97 fps - 1280x720 progressive, 60 or 59.94 fps
RS-232 Port	- 9-pin female DB9 - Standard pinout
Sync & Reset Port	- 3-pin female circular connector - LVTTTL synchronization output - TTL reset input (active high)
Video Latency	<i>Maximum delay between video input and output:</i> 1 camera frame time + 1 HD-SDI frame time
Color Processing	- Bayer reconstruction - Manual white balance using pushbutton switch
Configuration	Via rear-panel switch settings
Power Supply	Universal wall style w/ multi-nation outlet plug set
Power Plug	2.1 x 5.5 mm, center-positive. Locking style optional.
Power Requirements	5 VDC, 530 mA (typical)
Cabinet Dimensions	4.92" (L) x 1.46" (H) 6.00" (D)
Weight	14 oz
Operating Temperature Range	0 to 50° C
Storage Temperature Range	-25 to 75° C
Relative Humidity	0 to 90%, non-condensing

5. Interface

5.1. Front Panel Connections

The CLT-371A Camera Link Translator front panel is shown in Figure 5-1. The front panel contains a 26-pin MDR video connector for connecting to the Camera Link camera, a standard 75-ohm BNC connector for connecting to an HD-SDI device, and a 3-pin circular connector for sync output and reset input. The front panel also incorporates 3 LED status indicators and a white balance pushbutton switch.

The MDR-26 female video connector and signal assignment comply with the Camera Link specification for the “base” configuration.

The sync/reset connector is a 3-pin male locking circular type. Figure 5-2 identifies the pin assignments. Mating connectors are the Switchcraft TA3F’s (i.e., p/n TA3FSH). Use of this connector is optional.

The “PWR” LED illuminates following power-up initialization. The “CAM” LED illuminates when active camera video is detected. The “SYNC” LED illuminates when synchronization of the camera input to the HD-SDI output is detected.

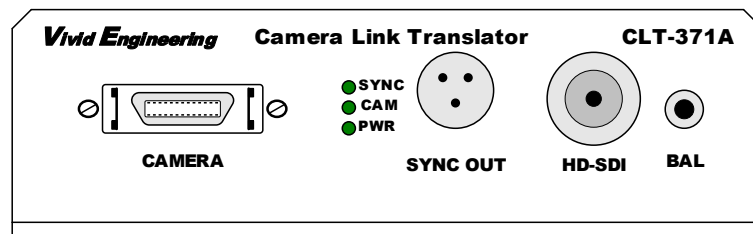

Figure 5-1: CLT-371A Front Panel

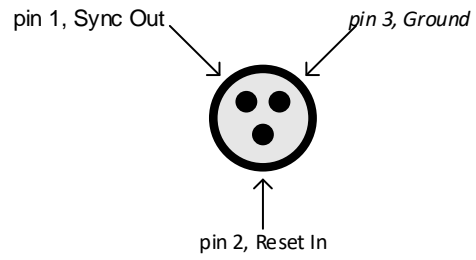

Figure 5-2: Sync/Reset Connector Pins

5.2. Rear Panel Connections

The CLT-371A Camera Link Translator rear panel is shown in Figure 5-3. The rear panel contains an RS-232 port, a 12-position (camera) mode switch, an 8-position (HD-SDI) mode switch, and the DC power jack.

The DC power jack accepts either a standard 2.1 x 5.5 mm barrel-style power plug or a special locking plug. The locking plug has bayonet-style “ears” on the barrel. Once inserted, the plug is turned ¼ turn clockwise. This locks the connection and provides retention. Plug polarity is center-positive. Recommended locking power plug is Philmore part number 2150.

The RS-232 port connector is a standard 9-pin female D-Sub type (DB9). Table 5-1 identifies the DB9 pin assignments.

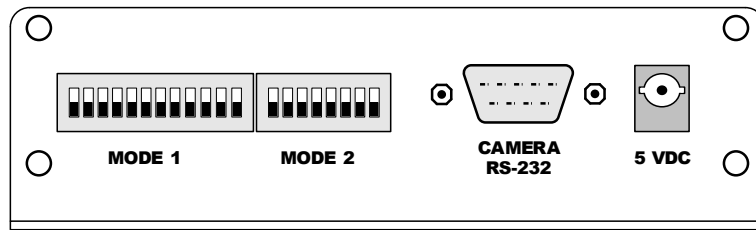

Figure 5-2: CLT-371A Rear Panel

Table 5-1: RS-232 Port Definition

Signal Name	DB9 Pin#	Signal Direction	Notes
Serial Transmit Data	1	Output	<i>received from camera</i>
Serial Receive Data	2	Input	<i>sent to camera</i>
Ground	5	N/A	

6. Mechanical

6.1. Dimensions

The CLT-371A Camera Link Translator cabinet dimensions are shown in Figure 6-1.

The CLT-371A is housed in a sturdy aluminum enclosure. The body is extruded aluminum, with detachable front and rear endplates. The enclosure incorporates a mounting flange. The flange contains four predrilled holes for mounting.

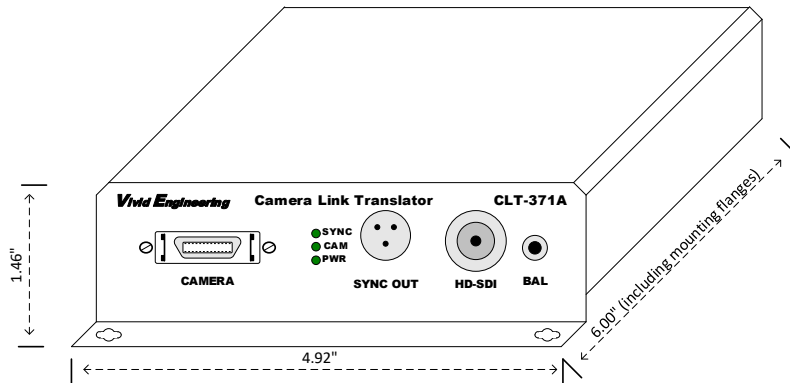

Figure 6-1: CLT-371A Cabinet Dimensions

6.2. External Power Supply

The CLT-371A is powered by 5 VDC and incorporates a 2.1 x 5.5 mm DC power jack that accepts either a standard barrel-style power plug, or a special locking version. Power plug polarity is center-positive.

The CLT-371A includes a multi-nation wall-mount power supply that handles a wide power range (90-264 VAC, 47-63 Hz) and comes with a set of outlet plugs suitable for most countries (US, Europe, UK, etc). The CLT-371A may also be purchased with a locking-plug power supply, or without power supply. The locking plug reduces the risk of accidental disconnection from the rear-panel power jack.

7. Revision History

Table 7-1: CLT-371A User's Manual Revision History

Document ID #	Date	Changes
201488-0.1	8/31/2023	Preliminary release of manual